

# STEDMAN

# MEGA-SLAM™



- Solid Rotor
- High Capacity
- Easy Maintenance
- Large Intake Capacity

## When Productivity is Your "Primary" Consideration

Stedman's Mega-Slam™ effectively handles feed sizes beyond the range of conventional secondary crushers. So effectively that now you, the producer, can purchase a crusher that in many crushing operations will eliminate the need for primary size reduction equipment.

With a large feed opening and solid rotor design, the Mega-Slam offers increased feed size capability.

A few installations include limestone, gravel, asphalt, shale, aluminum dross and lead slag.

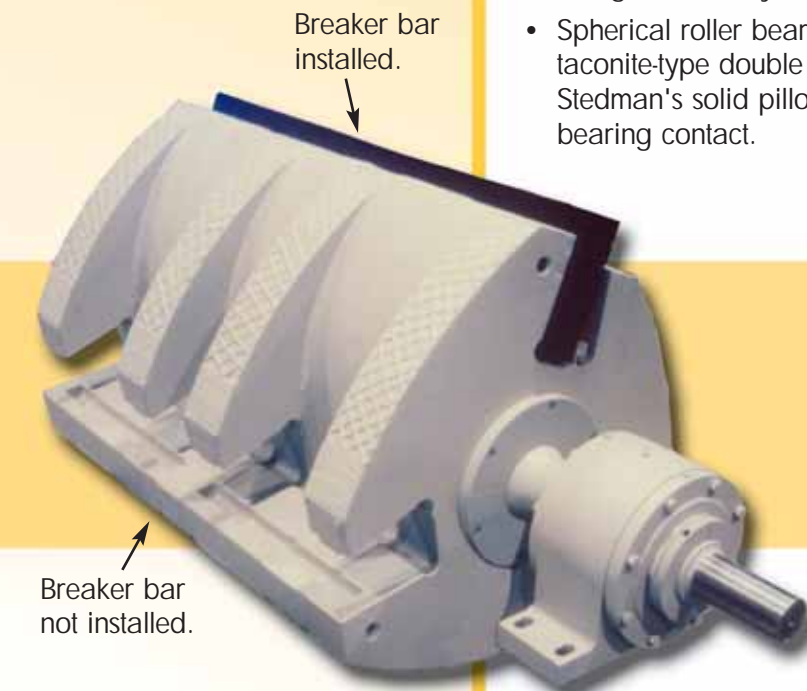

# Mega-Slam™ Delivers More Than Anything

## 21st Century Performance

The Mega-Slam is designed specifically to increase profits by maximizing the production of marketable cubical product. Backed by over 170 years of industry experience, the Mega-Slam provides efficiency, economy and durability through selective reinforcement of critical components.

Features such as the solid rotor design, reversible manganese monoblock aprons, and interchangeable side liners assure the highest levels of performance. The Mega-Slam is designed for low maintenance and simplified interior access to breaker bars, primary and secondary aprons and side liners.

## Superior Solid Rotor

- Contoured, computer designed for maximum efficiency.
- Proven positive breaker bar holding device with buried wedges minimizes wear as well as breaker bar installation, removal and indexing time.
- Solid rotor weldment is stress-relieved, balanced and magnetic particle tested.
- Interchangeable breaker bars are available in manganese, alloy steel and hi-chrome.
- Spherical roller bearings are grease lubricated with taconite-type double cavity block seals mounted in Stedman's solid pillow blocks for a positive 360° bearing contact.

# MEGA-SLAM

**Primary/Secondary  
HSI Solid Rotor**



# More Punch For Your Buck Else In Its Class.

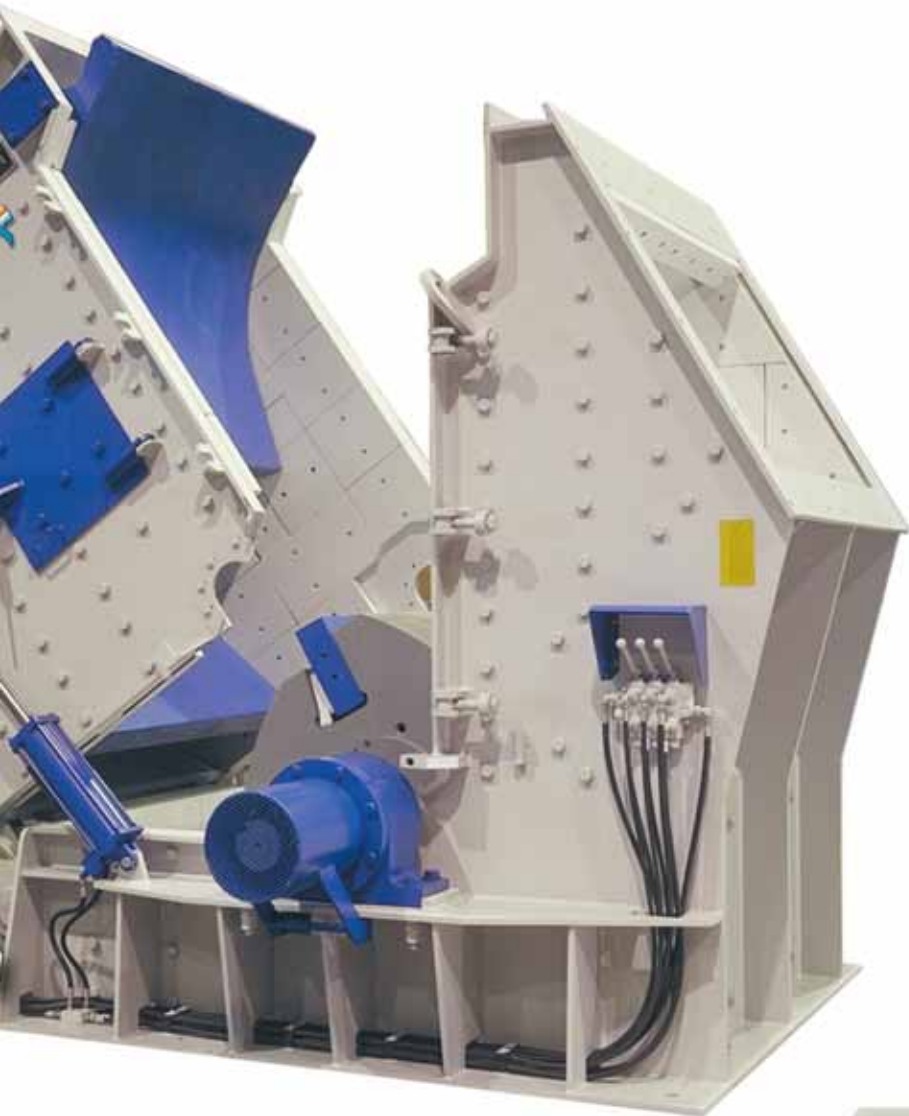

## Dependable Product Control and Rugged Wear Parts

- Heavy duty, reversible monoblock manganese aprons.
- Optional three inch thick replaceable secondary apron breaker plates.
- Standard rear apron spring bridge assembly assures accurate product control.
- Interchangeable housing liners are two inch thick hi-chrome or alloy steel.

## Fast Apron Access & Adjustment

- Hydraulic pump allows one person opening of the hinged rear housing.
- Side doors, double rear doors and large roof hatch permit unexcelled access for inspection and adjustment of gap settings.
- Hydraulic assist pump allows easy gap adjustment for both aprons, assuring superior product control.



# Mega-Slam™ Specifications<sup>1</sup>

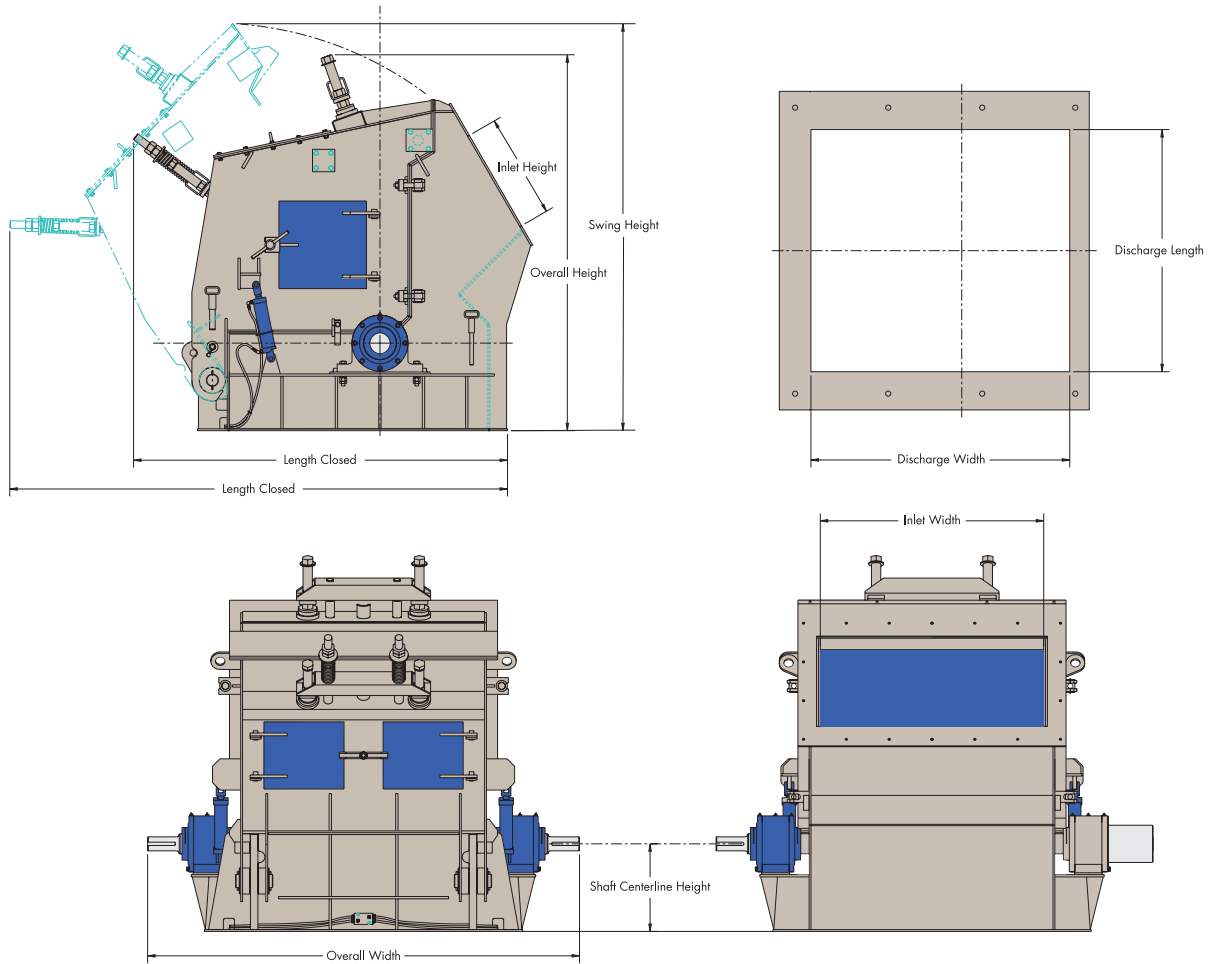

Model Number	Rotor Dia. x Rotor Width	Capacity Range TPH <sup>2</sup>	Net Inlet Opening W x H	Net Discharge W x L	Height			Width Overall	Length		Crusher Weight Lbs.
					Shaft $\varnothing$	Overall	Swing		Closed	Open	
MS4230	42 x 30	100 - 125	31 x 28	65 x 40	24	89	109	83	106	140	22,000
MS4260	42 x 60	175 - 200	61 x 28	65 x 70	24	89	109	113	106	140	31,000
MS4860	48 x 60	250 - 300	61 x 34	65 x 82	25	113	123	116	109	141	45,000
MS5460	54 x 60	350 - 500	61 x 40	65 x 91	31	138	144	128	118	177	65,000
MS6460	64 x 60	550 - 700	61 x 46	65 x 105	36	157	169	137	139	203	83,000

<sup>1</sup> Technical data subject to change without notice. All dimensions in inches unless otherwise noted. Caution: Do not use these dimensions for construction purposes.

<sup>2</sup> Medium limestone. Throughput capacities may vary depending on feed size, feed rate, operating conditions, physical characteristics of the feed material and breaker bar gap settings.

## Customer Service Testing Facility

We invite you to send a sample of your feed material for evaluation in Stedman's Customer Service Testing Facility. All tests will be run in a full-size production model "GS" mill. Contact Customer Service Testing at the address below for more details.



# 1-800-262-5401

STEDMAN • P.O. Box 299 • Aurora, IN 47001 • Toll free: 800-262-5401 • Fax: 812-926-3482  
 Email: sales@stedman-machine.com • Internet: www.stedman-machine.com